

Features:

- A/D 16 bit 225kHz per channel 16SE
- D/A 16 bit 100kHz 4 channel
- TTL in/out 24 bit
- 2 counter 32 Bit , 3 internal counter (DSP)
- External trigger/clock and synchronization
- optional:
 - Signalprocessor DSP56301 100MHz, 1,5 MByte SRAM
- 2 rotary encoder counting 32 bit with 32 bit timestamp

Online-Functionality:

- The boards are offering the following features
- Mathematical functions like filter PID and FFT
- Operating functions like triggering and PWM
- Realtime-PID-controller
- Scaling functions like characteristic
- Clocking the A/D converter polling, controlled -timer, external clock source
- Trigger (window and edge triggering at all measurement types)
- Analog and digital PWM
- Simultaneously acquisition of digital-, counter- and analog signals
- Functiongenerator:
- Output of sine, triangle, square, pulse, sawtooth, noise and files
- Online-scaling of the measurement data
- Realtime-FFT-, IIR- and FIR-filter
- Realtime-oversampling
- Digital onboard controlling

One
realtime
function
for free

Analog In	
number of Inputs	16 single-ended
resolution	16 Bit
A/D throughput	225kHz per channel (3,6MHz)
input voltage range	±10V; ±5V
system accuracy	0.01 % = 2,8 mV
ADC sample rate	4 µs
input impedance	1 G, 30 pF

Smart PCI data acquisition card, with digital signal processor MotorolaDSP56301(100MHz), 1.5 MB RAM, 16 single-ended analog inputs. All input channels are sampled simultaneously, 225kHz sampling rate per channel, the total sampling rate is 3,6MHz. The resolution of the AD and DA converter is 16 bits, inputvoltage ranges are ± 5V or ± 10V. 4-channel DA converter, conversion rate of 100 kHz, 16 bit, the output voltage range is ± 10V, 24 digital channels, bitwise configurable as input or output. External trigger and clock configurable for automatic measurements. Two 32-bit counter channels: 50MHz event counter, frequency counter (resolution 10Hz, optional resolution: 1/10/100/1000Hz), period counter and pulse width measurement, resolution 20 ns. Optional: 2 Channels 32-bitIncremental encoder, 1x, 2x, and 4x interpolation programmable, maximum input frequency 10MHz, reset detection, 100ns time stamp resolution. The time stamp enables highly accurate speed measurement. Optional PWM signal output in the range of 1 Hz to 2.5 Mhz, includes one online function (please specify when ordering): PID controller, Digital Filter (FIR/IIR), linearization of the measured values or FFT on the "HS" cards.

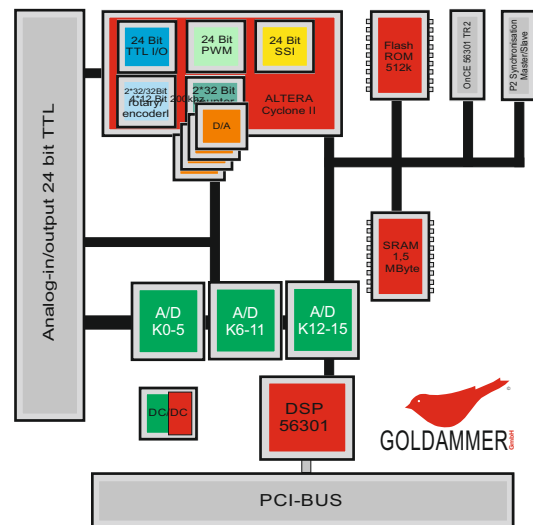

Applikationssoftware

DASYLab
DIAdem
EdasWin
LabVIEW
LABWindows/CVI

E.d.a.s.WinPlus TM 

DASYLabTM
Data Acquisition System Laboratory

NATIONAL INSTRUMENTSTM
DIAdem

NATIONAL INSTRUMENTSTM
LabVIEW

API für C/C++, Delphi, Python
unter Windows und für DotNET
(C#, F#, VB.NET, IronPython, ...)



Analog In	
maximum input voltage in	
operation operating	±13,5 V
maximum input voltage in	
operation non operating	±2 mA
optional G06-30D0-0	±35,0 V
BIAS current	±40 nA
non linearity	±3 LSB
digitalization error	±3 LSB
quantisation error	< ±1 LSB
range error	adjustable
quantisation error	adjustable
A/D-zero drift	±7 ppm / °C
monotonicity	±1,5 LSB
terminal connection	SUB-D-50 shielded

Analog Out	
number of outputs	4
resolution	16 Bit
DA throughput	100kHz per channel
output voltage ranges	±10V
output current	±5 mA
output impedance	0.2 Ohm
range error	< ±0.1 %, typ.
zero error	< ±0.1 %, typ.
settling time up to 0.012 % FSR	10 µs, 20V step
steepness	10 V / µs
AD Zero drift	±5 ppm / °C, typ.
field drift	±5 ppm / °C, typ.
monotonicity	guaranteed

Digital Inputs/Outputs	
number of inputs	24 (switchable per bit)
logic family	LVC MOS
logic sense	2.0 V
logic low input voltage	0.4 V
logic high input current	0.5 µA
logic low input current	0.1 µA
logic high output voltage	3.1 V min.
logic low output voltage	0.1 V max.
logic high output current	-2,5 mA
logic low output current	-2,5 mA
termination	None
maximum input voltage	
in operation	+5 V
synchronous capture	of digital and counter inputs simultaneously to analog inputs

*

Digital outputs with option EIPL-30GI-0	
number of outputs	12 (direct controls of relays)
number of outputs	8 (direct controls of relays)
external supply	external voltage 3.3V to 30V
output current	60mA per channel
maximum external voltage	+30 voltage
terminals Weidmüller	screw terminals
optical isolation	cutoff voltage 1000V

Digital inputs with option EIPL-30GI-0	
number of inputs	12+2 optical isolation inputs
logic sense high	from 2.4V to 28V
input current	2,4V ≈ 3 mA, 28V ≈ 11mA
maximum external voltage	+30V
input frequency max.	10MHz
terminals Weidmüller	screw terminals
optical isolation	cutoff voltage 1000V

Trig. Trigger	
logic family	properties see digital input/ output
input	1 trigger input
output	1 trigger output
	master/slave programmable

PWM Pulse width modulation*	
channels	1
resolution	24Bit in 100ns steps
range	2Hz - 250kHz
logic family	LVC MOS output

Pin assignment P1

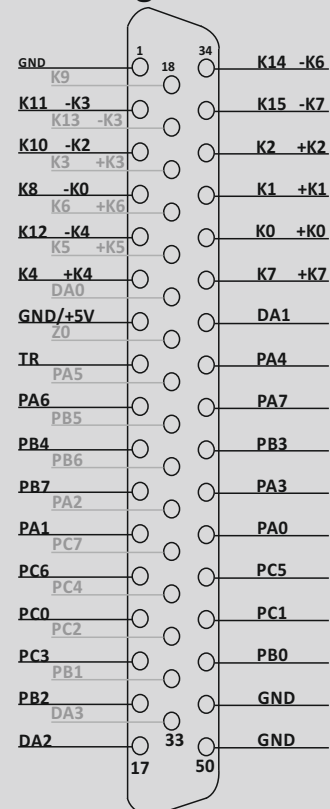

Sync Synchronization	
logic family	properties see digital input/ output
input	1 synchronization input
output	1 synchronization output
	master/slave programmable
	all devices from the series G06, G0E, G07, G09 synchronized with each other.

Counter	
logic family	properties see digital input
number of counters	2
resolution	32 Bit
counter resolution	10/50 MHz
counter modes	event counting, frequency measure- ment (frequency resolution 10Hz)
	optional* pulse width, periodlength

rotary encoder counting*	
number of inputs	2 rotary encoder + 1 time stamp
resolution	2 * 32 Bit rotary encoder counter
resolution	2 * 32 Bit time stamp
resolution time stamp	100ns
mode time stamp	time stamp/flow
interpolation	1x, 2x, and 4 * programmable
zero (counter clear)	programmable
input frequency max.	20MHz

Others:	
bussystem	PCI.Rev, 2,1
signalprocessor	56301 100Mhz, 100MIPS
memory	1,5 MByte
flash	512 kByte
dimensions	142 x 88 mm
Connections	SUB-D 90 shielded
RoHS konform	yes
weight	ca. 150g.
inputcurrent	+5V, max. 600mA
customs tariff number	84733020

Pulse width modulation*

MultiChoice can output PWM signals with a resolution of 100ns and output frequencies between 2Hz up to 2,500,000Hz. Pulse width modulation is a kind of special feature in the world of measurement. It is a design of Goldammer GmbH. For this kind of pulse width modulation no interruptions or pulse discontinuities are permitted. If frequency or pulse width is changed, the actual period is emitted until it is fully completed and then the new settings are used without any discontinuities. Modulation of frequency and pulse width is supported at the same time and it is fully transparent to the user who only specifies a frequency and the pulse width in percent. If the frequency is changed the percentage is kept, if the pulse width is changed, the corresponding frequency is kept.

Ordering information hardware-extensions::	
G06-1044-1	1950,00€
12 Bit A/D, 12 Bit D/A, 24 DIO, 2 Counter	
K00-1012-0	115,00€
50 pin connection panel for DIN rail mounting with cable	
EIPL-3000-0	299,00€
BNC-Connection unit	
K00-1011-0	45,00€
50 pin round ribbon cable	
G06-3090-0	255,00€
24 Bit Frequency measurement resolution 1/10/100/ 1000Hz o. pulse width and period length ref.100ns	
G06-30A0-0	99,00€
1-Channel. PWM 2Hz-2,5MHz	
G06-30I0-0	149,00€
2-Channel . rotary encoder with time stamp 1/2/4 x Interpolation Reset.	
G06-30D0-0	149,00€
With voltage resistant multiplexers ±40 V	
G06-4010-0	400,00€
Realtime-FFT	
G06-4020-0	400,00€
Online-scaling of the measurement data	
G06-4030-0	400,00€
Realtime-FIR-and IIR-filter	
G06-4040-0	400,00€
Realtime-PID	
G06-4050-0	800,00€
Functiongenerator	
Output of sine, triangle, square, pulse, sawtooth, noise and files	
G06-40x0-0	1600,00€
All functions to the package price	

For additional accessories and options please refer to the price list.

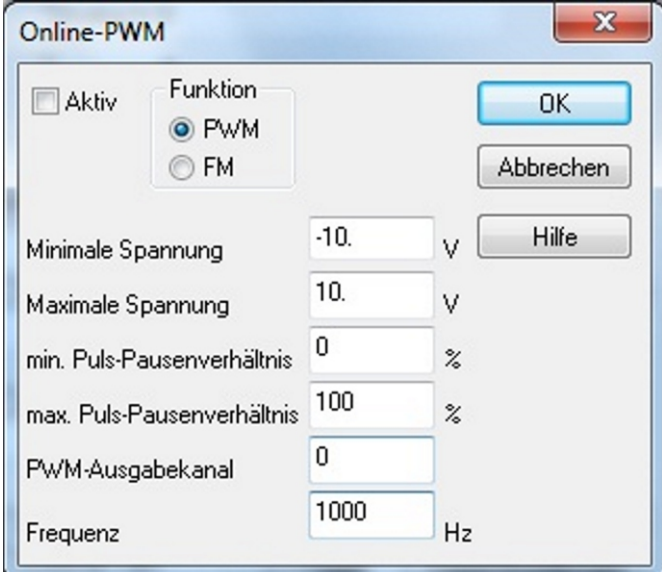

The screenshot shows a software window titled "Online-PWM" with a close button (X) in the top right corner. The window contains the following controls:

- An "Aktiv" checkbox is checked.
- A "Funktion" section with two radio buttons: "PWM" (selected) and "FM".
- Buttons for "OK", "Abbrechen", and "Hilfe" are located on the right side.
- Input fields for:
 - Minimale Spannung: -10. V
 - Maximale Spannung: 10. V
 - min. Puls-Pausenverhältnis: 0 %
 - max. Puls-Pausenverhältnis: 100 %
 - PWM-Ausgabekanal: 0
 - Frequenz: 1000 Hz

Online functionality

The measurement cards offer a wide variety of online functions like filters, signal analysis like FFT, control algorithms (PID), and threshold observation. Any of these functions are run on the signal processor without any effort of the PC. So any of the measured values can be processed immediately after measuring it.

A controller is able to adjust the manipulated value in an extremely short period of time if the input value changes respectively. For none of these operations any effort has to be made by the PC. The processing of data is achieved immediately after measuring it without any additional delay. Filters suppress undesired frequencies and distortions. Therefore the user gets useful data only. A combination of filters and controllers permit to remove distortions first and depending on the data to control the control loop then.

All of these functions are part of the boards without any additional hardware. So distortions caused by cabling, signal conditioning inbetween, or several contacts are avoided. Furthermore the delay between input and output is extremely short which permits real time control. Sometimes the different time associations of measurement hardware of different manufacturers can lead to problems.

If analog channels, digital inputs and counter readings are measured with different components it is normally impossible to associate this signals to a certain time. This gap is closed by MultiChoice too. The signal processor offers the possibility to observe digital inputs and counter signals like analog inputs and to measure data with synchronized time. Channels of any type are measured and stored as a single sample which ensures time synchronization.

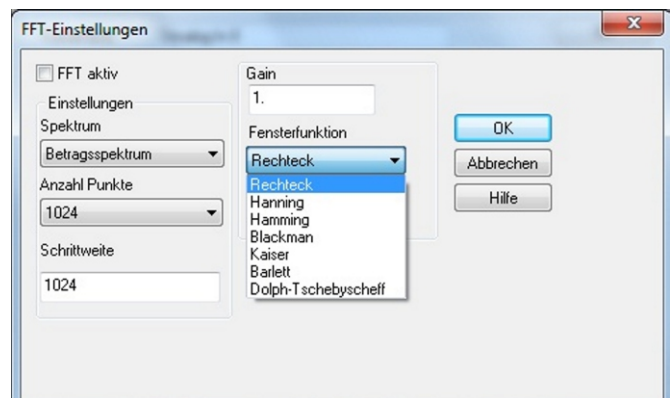
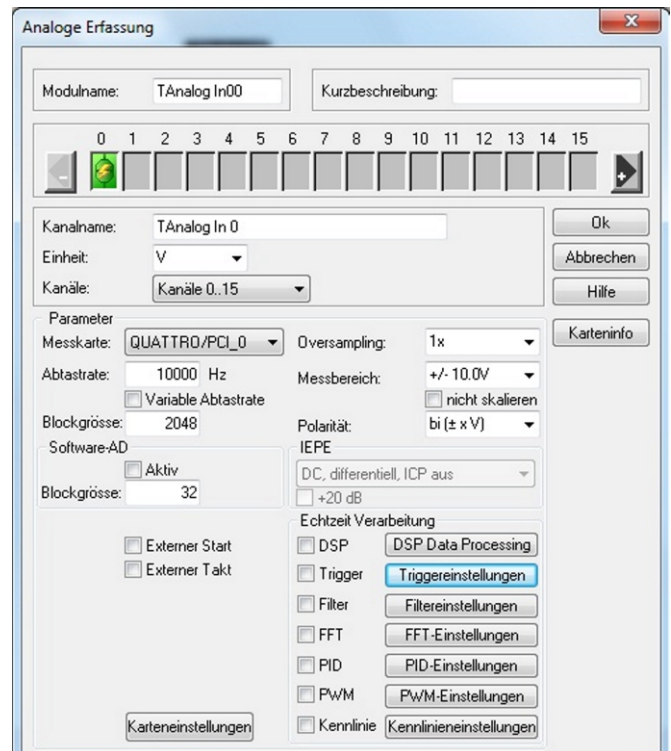

Trigger:

There are several trigger conditions available: Borders, threshold checking, checking of edges, limits, or window conditions. Measured data can be processed mathematically and in dependence of the steepness of the resulting curve (steepness of gradient), processing can be initiated even in threshold and window conditions. Trigger conditions becoming true can start or stop a measurement, can set digital outputs or control analog outputs.

As an option trigger conditions can activate or deactivate themselves crossover. So a network of dynamic triggers is available depending on the proceedings of the measurement.

Trigger conditions can be configured to be retriggerable. After a certain condition becomes true, they are activated or deactivated to achieve the same or a changed observation.

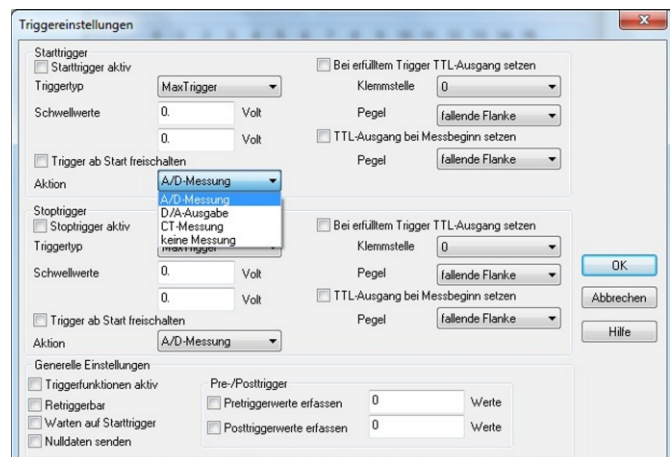

Connectivity technology:

EIPL-3000-0 275,00€

Passive(Active) BNC-connector chassis with 50 pin Sub-D connector. The analog channels are connected to BNCconnectors on the top of the case. The digital channels are connected to detachable Weidmueller screw-terminals on the left side of the case. The box can be switched between 16 analog single-ended input channels or 8 analog differential input channels. 24 digital TTL I/O-channels, 2 counter channels, 1 trigger-channel. Dimensions 180 x 118 x 64 mm

K00-2011-0 34,00€

50 pin round ribbon cable used to connect the analogue and digital channels of the PCI Light/quattro (Multichoice IV) cards

Option:

EIPL-30GI-0 199,00€

Galvanic isolation of the digital I/O channels. 12 opto coupled input channels (Ue. 2,4 -30 Volt) Port (PB4 up to PC7, Z0 and Trigger), 12 opto coupled output channels 30V 50mA Port (PA0 bis PB3), 1 PWM channel. All channels are using the Toshiba TD62783 driver. All output-channels can be used to actuate relais.

EIPL-30DI-0 399,00 €

16 channel instrumentation-amplifier for BNC-version only. Each channel has its own instrumentation amplifier. Optional every input-channel can be equipped with its own voltage divider and amplifier. (instrumentation amplifier INA2128).

EIPL-30DI-2 399,00€

16 channel instrumentation-amplifier for BNC-version only. Each channel has its own instrumentation amplifier. Inputrange conversion from ± 50 Volt to ± 10 Volt. Optional every input-channel can be equipped with its own voltage divider and amplifier. (instrumentation amplifier INA2128)

EIPL-30DI-5 499,00 €

16 channel instrumentation-amplifier for BNC-version only. Each channel has its own instrumentation amplifier. Common mode voltage-range ± 100 Volt (instrumentation amplifier INA117)

EIPL-30C0-1 21,00€

160mm clip for wall mounting of the MC-Light-Compact case

B06-1011-0 82,00€

Converter MultiChoice III ISA to PCI-light G06-10XX-X

K06-1012-0 97,00€

50 pin connector-panel for top hat rail installation and 50 pin SUB-D connector cable used to connect the analogue and digital channels of the Multichoice IV PCI cards.

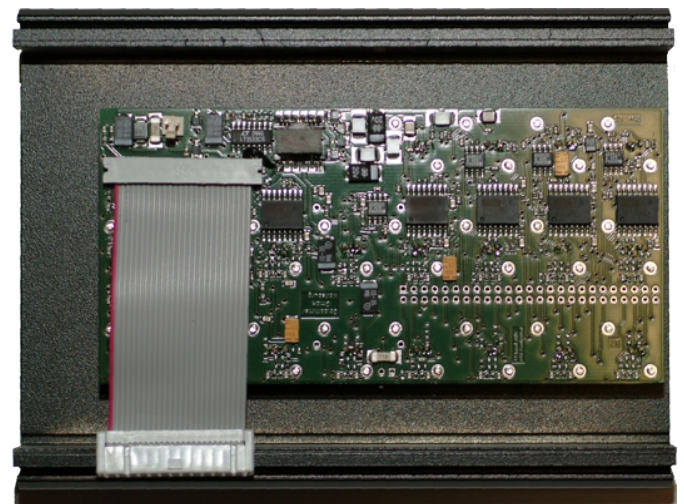
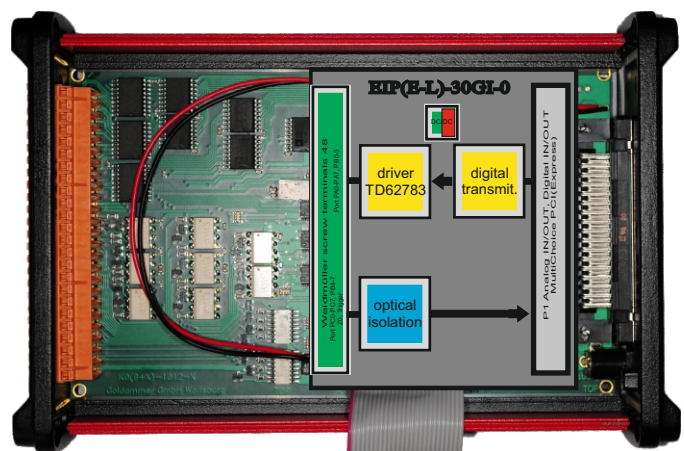

B06-1011-0

K06-1012-0

